



UNGARO

TERMOSTUFE A PELLETT

INDICE / INDEX

L'Azienda <i>The Company</i>	5
Tecnologia evoluta facile da installare <i>An advanced design that is easily installed</i>	6
Un doppio vantaggio per l'ambiente <i>A double advantage for the environment</i>	7
IDRO PELLETT PELLET WATER HEATERS	
Classic Maia 14	11
Classic Maia 24	13
Classic Maia 34	15
Style Maia 14	17
Style Maia 24	19
Style Maia 34	21
Design 14 - 24 - 34	23
Elementi arredo Design <i>Furnishing elements</i>	
Maiolica <i>Majolica</i>	25
Legno <i>Wood</i>	27
Living <i>Living</i>	29
YNCAS	31
IDRO LEGNA E PELLETT WOOD AND PELLETT WATER	
Classic Bico Fire 24	35
Classic Bico Fire 34	37
Style Bico Fire 24	39
Style Bico Fire 34	41
AIR LEGNA E PELLETT WOOD AND PELLETT ROOM HEATERS	
Classic Bico Air 16	45
Style Bico Air 16	47
CENTRALE TERMICA BASIC BOILER	
CTU 24 - 34	51
Schemi Tecnici <i>Technical details</i>	52
Esempio di allacciamento idraulico <i>Hydraulic connection example</i>	58



L'AZIENDA / THE COMPANY

Una storia attuale, una mission di valore.
A story of today, a worthwhile mission.

L'azienda Ungaro nasce nel 2002, sotto la guida di Antonio Ungaro, con una mission molto precisa, anche oggi più che mai valida e condivisa dall'intero staff aziendale: "Lavoriamo da sempre come protagonisti del calore domestico. Di quel calore scegliamo d'essere il cuore realizzando termostufe-idro a pellet e legno/pellet. Sistemi funzionali, facilmente installabili, a basso impatto ambientale e ad altissima resa. Termostufe-idro dalla solida e affidabile tecnologia e dal design sostenibile. Pensate per un mercato ampio e diversificato, che privilegia i risultati: comfort, risparmio, rispetto ambientale. Questa è Ungaro: dalla parte delle persone." Ungaro è un'azienda tutta italiana.

The Ungaro company was founded in 2002, under the guidance of Antonio Ungaro, with a very specific mission that is even more valid today and is shared by the whole staff of the company: "We have always worked as main players in domestic heating. From this we have chosen heating stoves as our core business-water heaters fuelled by pellets and wood/pellets. Systems that work, are easily installed, of low environmental impact and of very high output. Water heating stoves made with solid and dependable technology and enduring design. Created for a broad and diversified market that appreciates the results: comfort, savings, and respect for the environment. This is Ungaro: at the people's side." Ungaro is totally Italian.

Im Jahr 2002 wurde das Unternehmen Ungaro, unter der Leitung von Antonio Ungaro, mit einer sehr präzisen Mission gegründet, die heute mehr denn je gilt und vom gesamten Mitarbeiterteam geteilt wird: „Wir arbeiten seit je her als Hauptakteure im Bereich der Hauswärme. Und wir möchten der Kernpunkt dieser Wärme sein, indem wir Heizöfen fertigen-Wasserwärmetauscher für Pellets und Holz/Pellets. Funktionelle Systeme, leicht zu installieren, umweltverträglich und mit besonders hoher Leistung. Heizöfen mit Wasserwärmetauscher in solider und zuverlässiger Technik und in geeignetem Design. Für einen großen und vielseitigen Markt entwickelt, der folgende Ergebnisse abverlangt: Komfort, Energieeinsparung, Umweltschutz. Dies ist Ungaro: auf der Seite der Menschen." Ungaro ist ein rein italienisches Unternehmen.

Née en 2002, l'entreprise Ungaro a été créée par Antonio Ungaro, avec une mission bien définie, encore valable aujourd'hui et partagée par toute l'équipe de l'entreprise: « Depuis toujours, nous travaillons pour créer la chaleur de vos maisons et intérieurs. De cette chaleur, nous en avons choisi de nous concentrer sur le cœur même en réalisant des chaudières eau chaude à pellets et à bois/pellets. Des systèmes fonctionnels, faciles à installer, avec un impact sur l'environnement très réduit mais avec un rendement en chaleur très élevé. Les Chaudières eau chaude: une technologie résistante et fiable et un design écologique. Étudiées pour un marché vaste et diversifié qui privilégie les résultats: confort, économie d'argent, respect de l'environnement. Voilà, Ungaro se place du point de vue des gens». Ungaro est une entreprise Made in Italy.

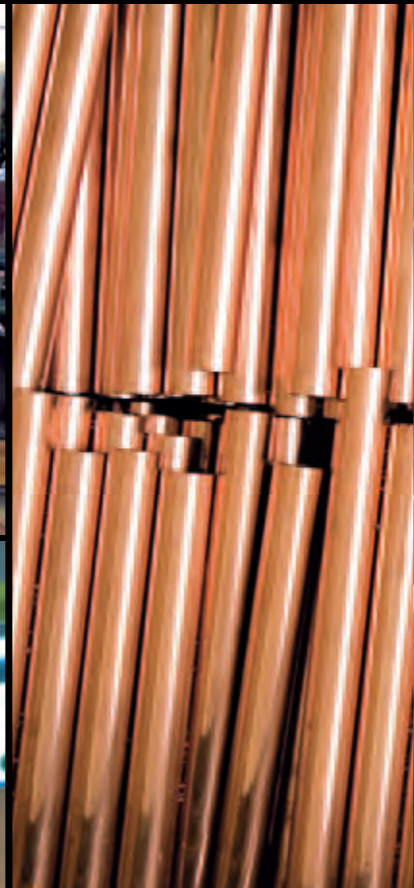

Tecnologia evoluta facile da installare.
An advanced design that is easily installed.

Tutte le termostufe-idro Ungaro si possono collegare ad impianti di riscaldamento esistenti. L'installazione è estremamente semplice e rapida, l'utilizzo facile e immediato e la manutenzione ridotta alle operazioni essenziali. Tutti i prodotti sono dotati di uno scambiatore di calore in rame che consente di ottenere il massimo del rendimento in brevissimo tempo, ogni modello può essere completato dal kit per la produzione di acqua calda sanitaria continua.

All Ungaro water heating stoves can be connected to existing central heating systems. Installation is extremely simple and rapid, for immediate and easy operation with maintenance reduced to the bare essentials. All products have a copper heat exchanger that allows them to quickly reach maximum output, every model can be fitted with a kit for continuously producing hot water.

Alle Heizöfen mit Wasserwärmetauscher von Ungaro können leicht an die bestehenden Heizungsanlagen angeschlossen werden. Die Installation ist extrem einfach und schnell, die Nutzung leicht und direkt und die Wartung auf die wesentlichen Arbeiten beschränkt. Alle Produkte sind mit einem Wärmetauscher aus Kupfer ausgestattet, der in kürzester Zeit eine maximale Ausbringung ermöglicht. Jedes Modell kann mit einem Durchlauferhitzer-Satz vervollständigt werden.

Toutes les Chaudières eau chaude Ungaro peuvent être raccordées à tout type de système de chauffage existant. L'installation est plus que facile et rapide, l'utilisation aisée et immédiate, quant à l'entretien, il est limité aux opérations de base. Tous les produits sont équipés d'une surface d'échange thermique en cuivre qui permet d'obtenir un rendement élevé en un temps record; chaque modèle peut être complété par un kit servant à la production continue d'eau chaude sanitaire.



Scambiatore aria in acciaio
Air exchangers in steel

Scambiatore acqua in rame
Water exchangers in copper

Sistema di pulizia semplificata
Simplified cleaning system

Entrata aria comburente
Inlet for combustion air

Cassetto cenere principale
Main ash pan

Cassetto cenere secondario
Secondary ash pan

Uscita fumi
Smoke outlet



Calore certificato.
Guaranteed heat.

Tutti i prodotti Ungaro sono certificati secondo le più rigide norme europee:

All Ungaro products are certified to be in accordance with the most rigorous European regulations:

Alle Ungaro-Produkte sind nach den strengsten europäischen Richtlinien sicherheitsgeprüft:

Tous les produits Ungaro sont certifiés conformes aux normes européennes les plus strictes:

EN 14785, EN 13240, EN 60335-1, EN 55014-1, EN 55014-2, EN 50165, EN 61000-3-2, EN 61000-3-3, EN 303 - 5



ISO 9001:2000



Un doppio vantaggio per l'ambiente.
A double advantage for the environment.

L'attenzione per l'ambiente è il principio guida della ricerca Ungaro. Un valore fondamentale che ha orientato l'azienda verso la produzione di termostufe ad altissimi rendimenti e bassissimi consumi, impiegando combustibili da fonti rinnovabili: la legna ed il pellet. Le nostre termostufe-idro a legna e a pellet sono progettate in modo da fornire comfort, distribuire acqua calda all'impianto idraulico, e cedere calore nell'ambiente. Ciò è reso possibile grazie ad una tecnologia avanzata ed innovativa che concilia così i vantaggi di combustibili sostenibili per l'ambiente, senza incrementare le emissioni dannose, le termostufe-idro Ungaro sono completamente eco-compatibili.

Care for the environment is the principal driver for Ungaro's research; a fundamental value that has directed the company towards the production of very high output, but low consumption, stoves using renewable fuel sources: wood and wood pellets. Our water-heating stoves with wood and pellets are designed to provide comfort, distributing hot water to the plumbing system whilst giving out heat to the surroundings. This output is possible because of advanced and innovative technology that permits the use of environmentally sustainable fuels without increasing dangerous emissions. Ungaro stoves are completely environmentally friendly.

Der Schutz der Umwelt ist der Hauptleitfaden der Ungaro-Forschung. Ein wesentlicher Grundsatz, der das Unternehmen in Richtung der Herstellung von Heizöfen mit hohen Ausbringungen und niedrigen Verbräuchen führt, indem Brennstoffe aus erneuerbaren Quellen genutzt werden: das Holz und die Pellets. Unsere Heizöfen mit Wasserwärmetauscher für Holz und Pellets sind so geplant, dass sie Komfort liefern, den sanitären Anlagen Warmwasser zuführen und Wärme in die Umgebung abgeben. Dies wurde dank einer fortschrittlichen und innovativen Technik möglich, die somit die Vorteile der erneuerbaren Brennstoffe mit der Umwelt in Einklang bringt, ohne dabei die schädlichen Emissionen zu erhöhen. Die Ungaro-Heizöfen mit Wasserwärmetauscher sind vollkommen umweltverträglich.

L'attention portée à l'environnement est le principe conducteur de la recherche Ungaro. Une valeur fondamentale qui a amené l'entreprise à s'orienter vers la fabrication de Chaudières à haut rendement et à basse consommation, et ce, grâce à l'utilisation de combustibles à base de produits renouvelables : le bois et les pellets. Nos Chaudières eau chaude à bois et à pellets ont été conçues pour un meilleur confort, pour permettre la distribution d'eau chaude vers le système hydraulique et pour chauffer l'environnement. Tout ceci, grâce à une technologie d'avant-garde et innovante qui permet d'allier les avantages de combustibles soutenables pour l'environnement, sans pour autant augmenter les émissions de substances nocives. Les Chaudières eau chaude Ungaro sont donc entièrement éocompatibles.

Classic Maia 14

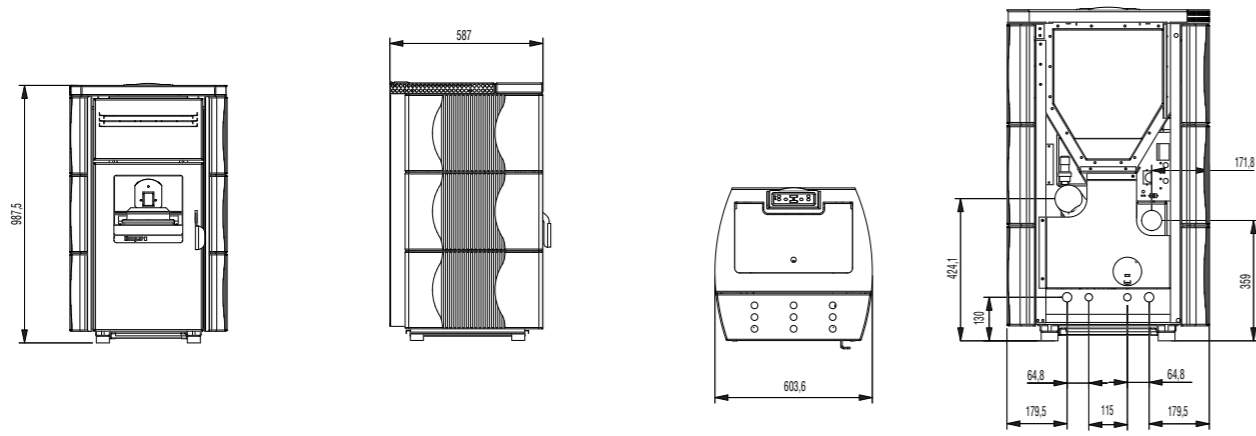

Style Maia 14

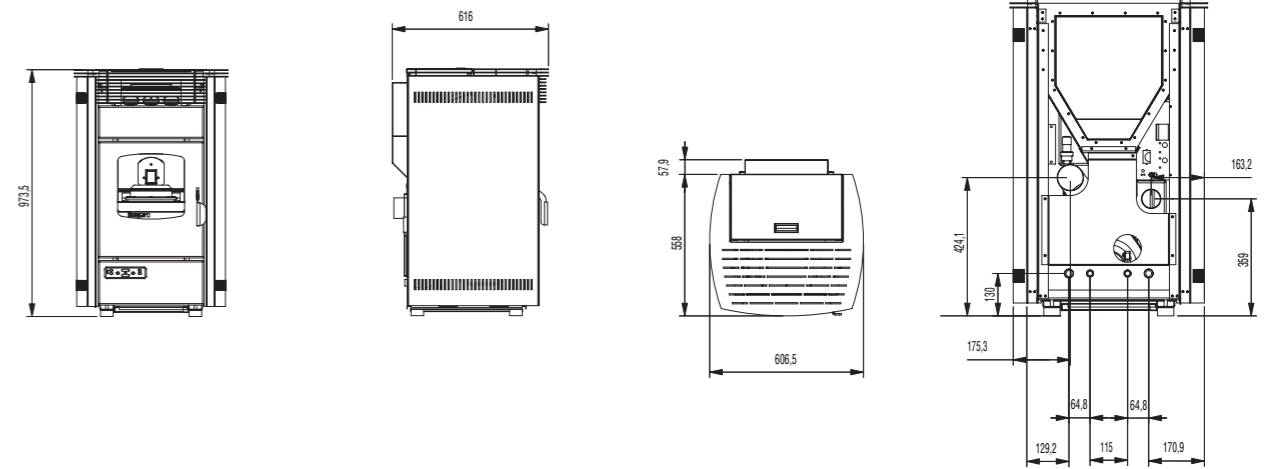

Classic Maia 24

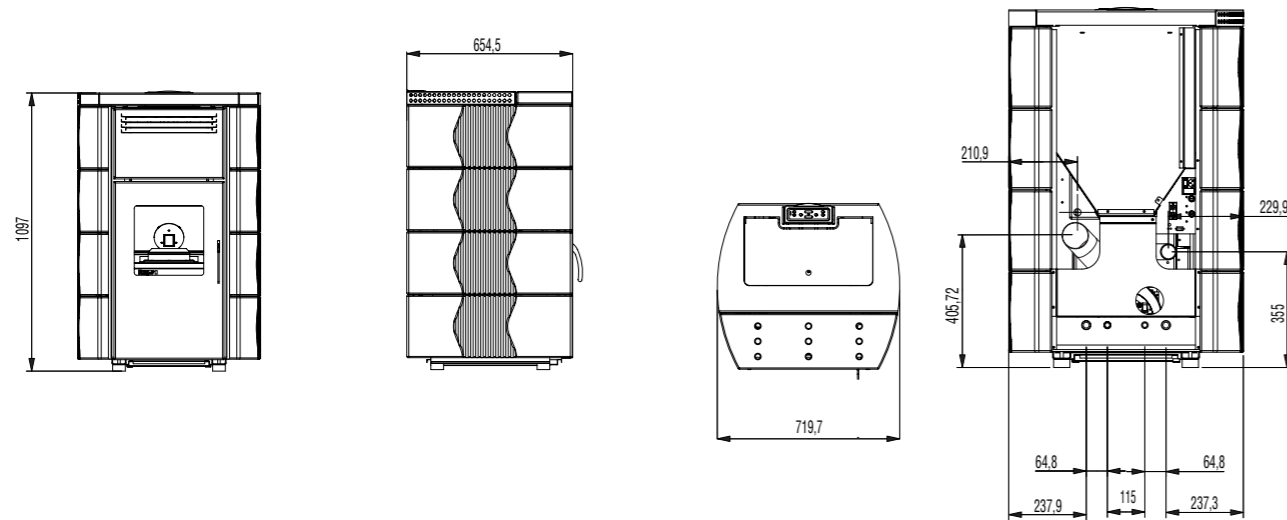

Style Maia 24

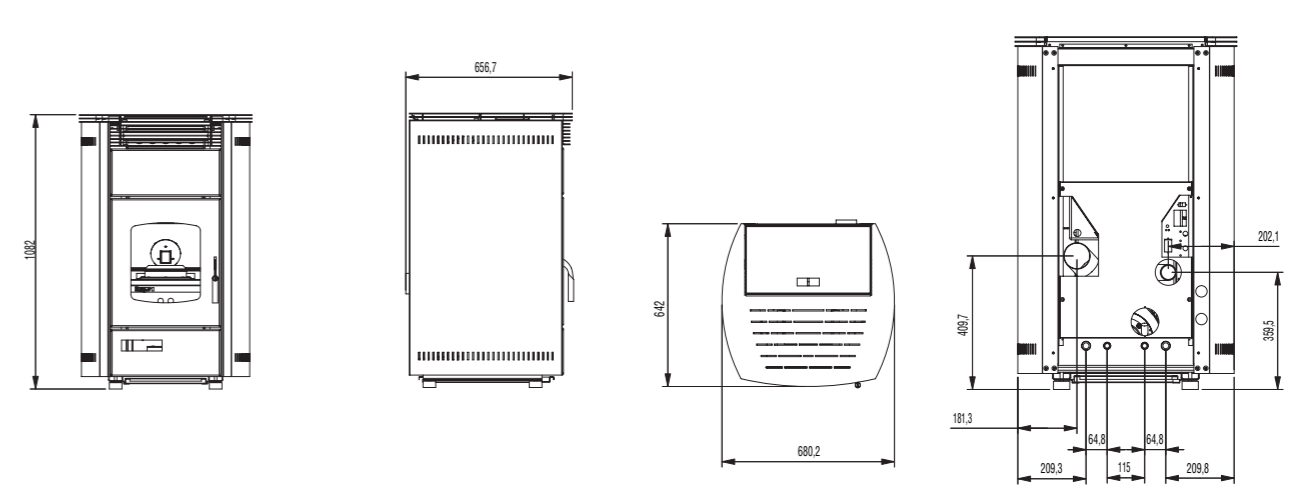

Classic Maia 34

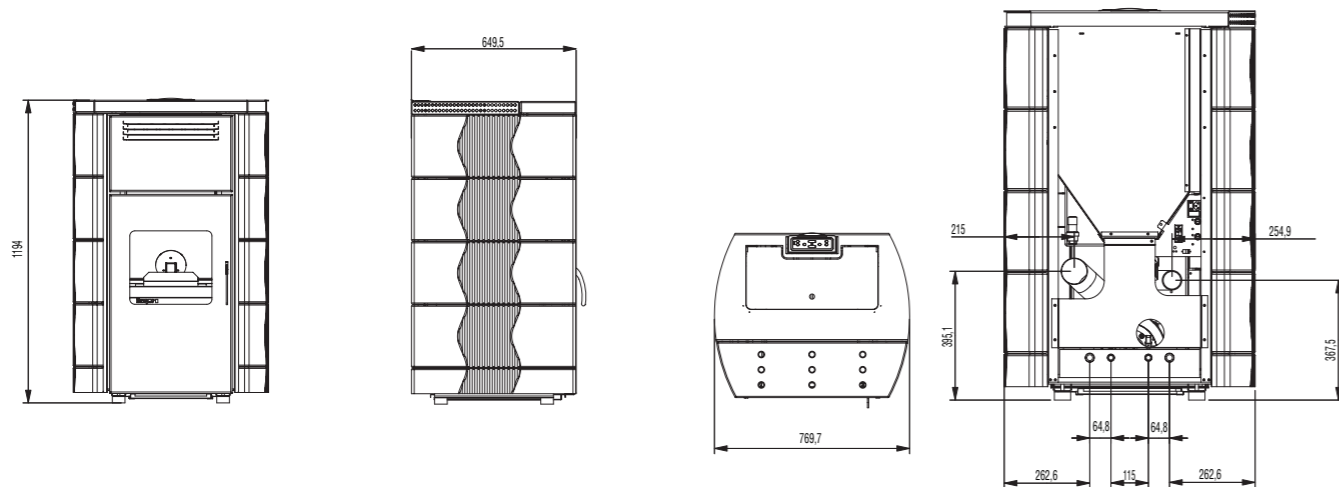

Style Maia 34

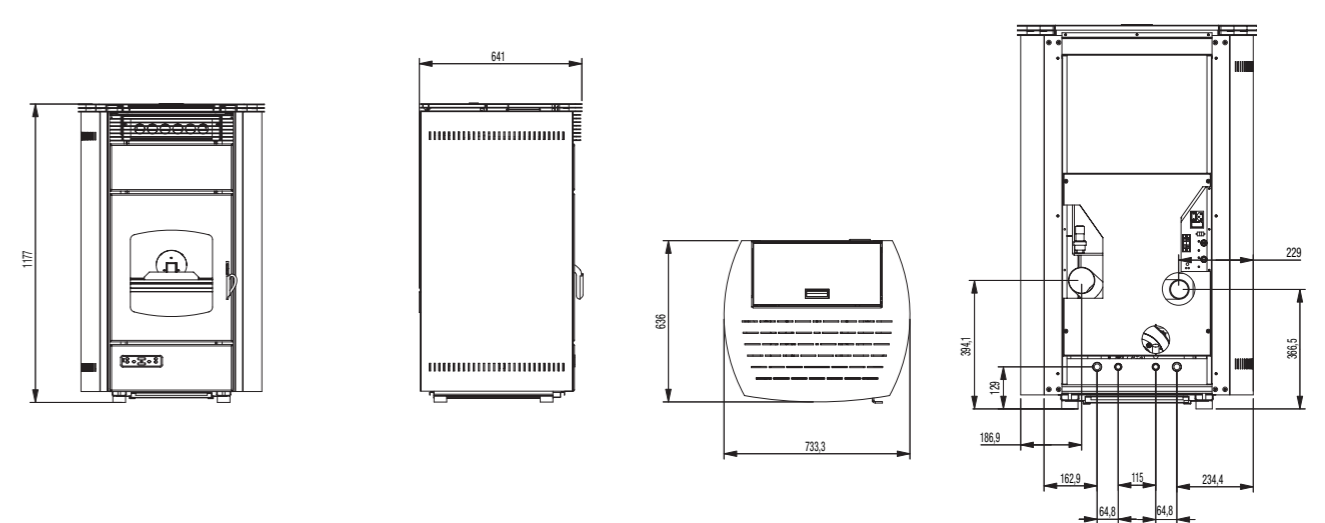

Misure espresse in cm
Dimensions expressed in cm

Design 14

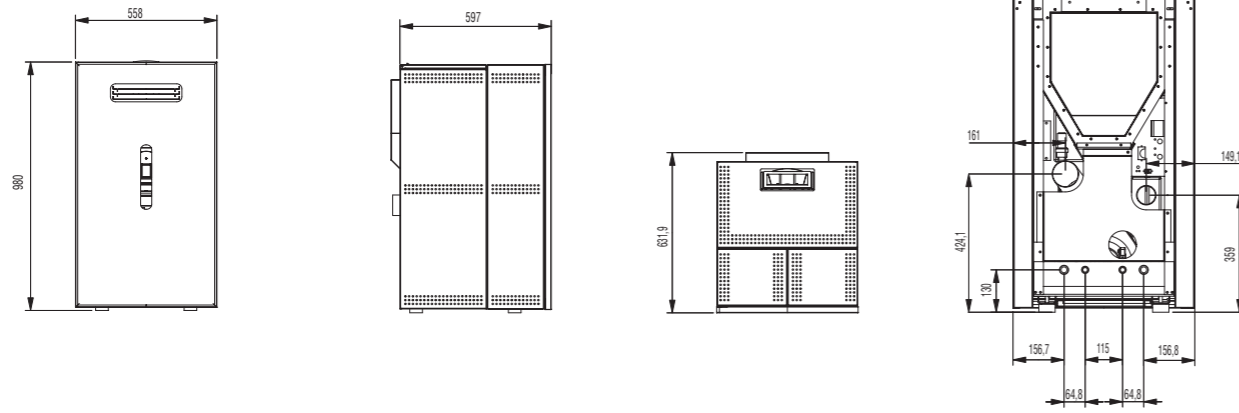

Classic Bico Fire 24

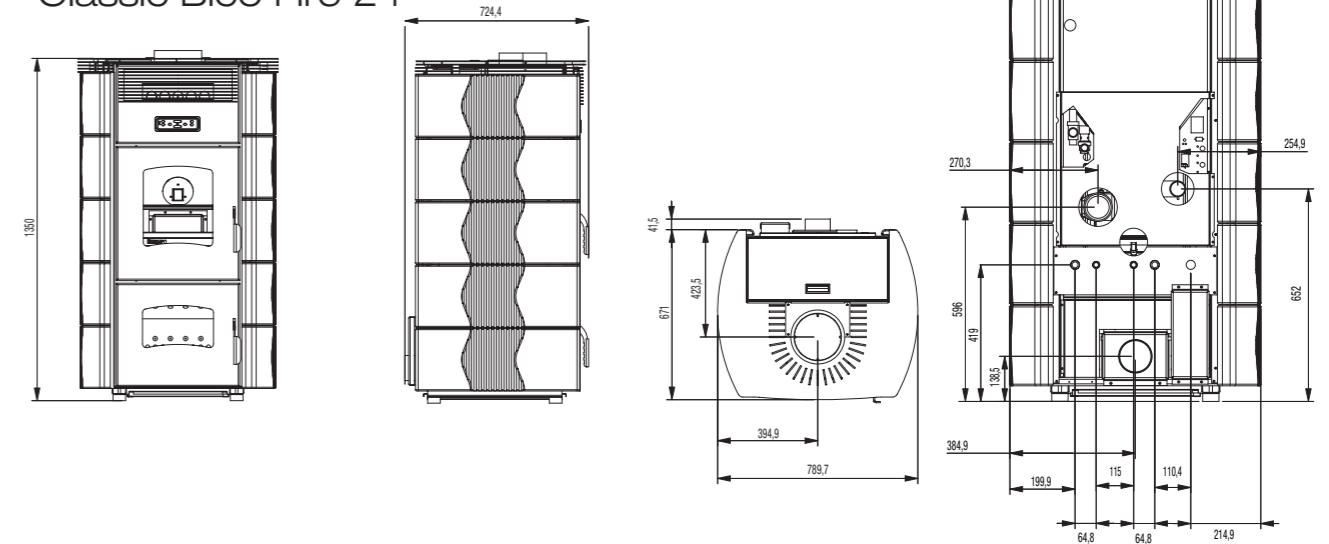

Design 24

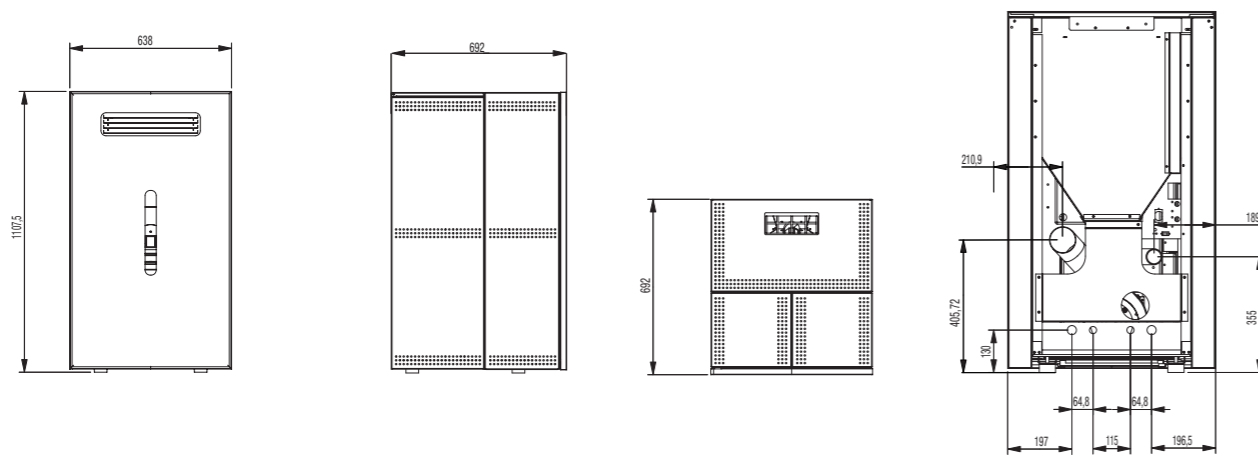

Classic Bico Fire 34

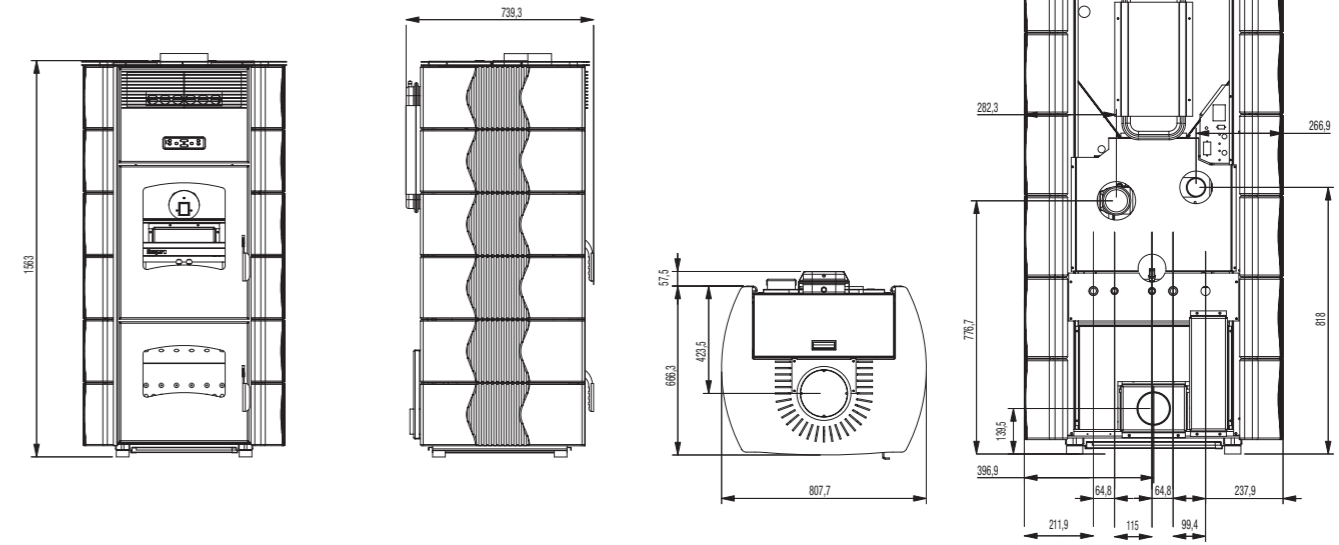

Design 34

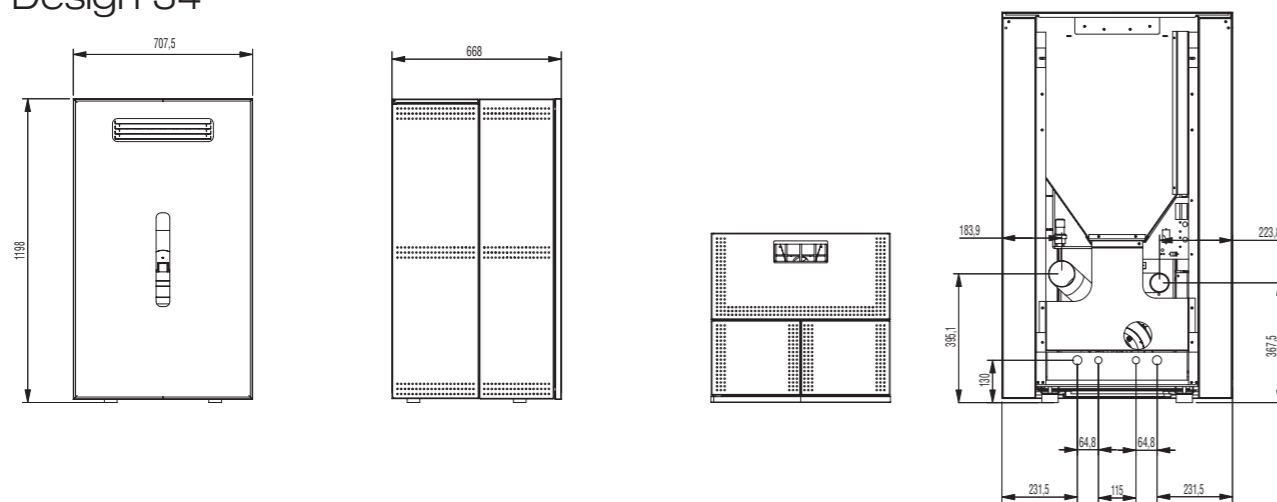

Style Bico Fire 24

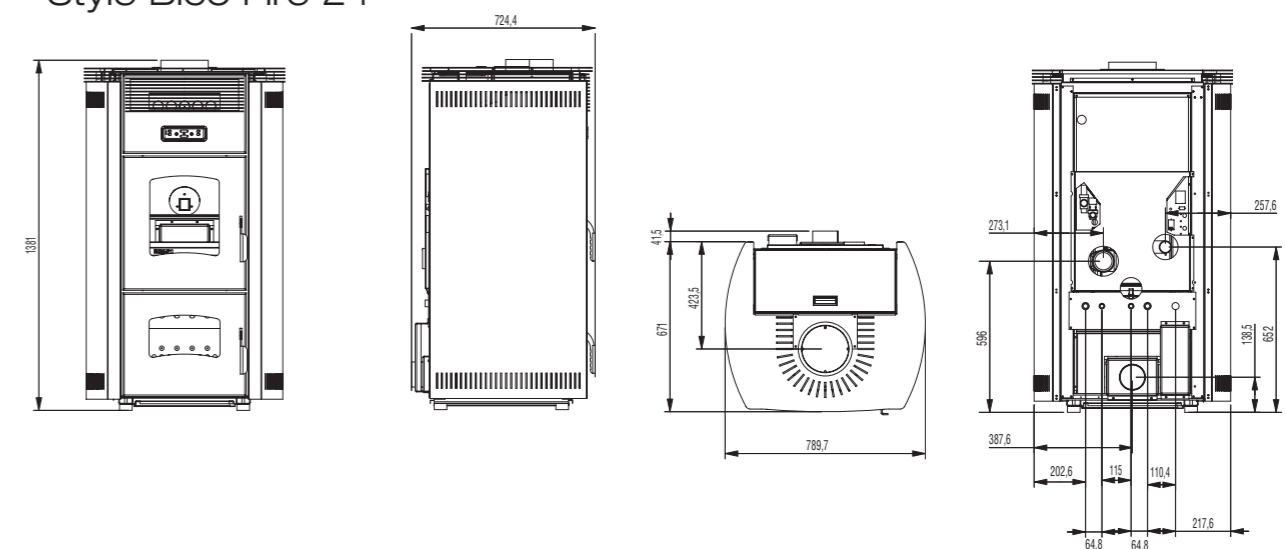

Misure espresse in cm
Dimensions expressed in cm

Style Bico Fire 34

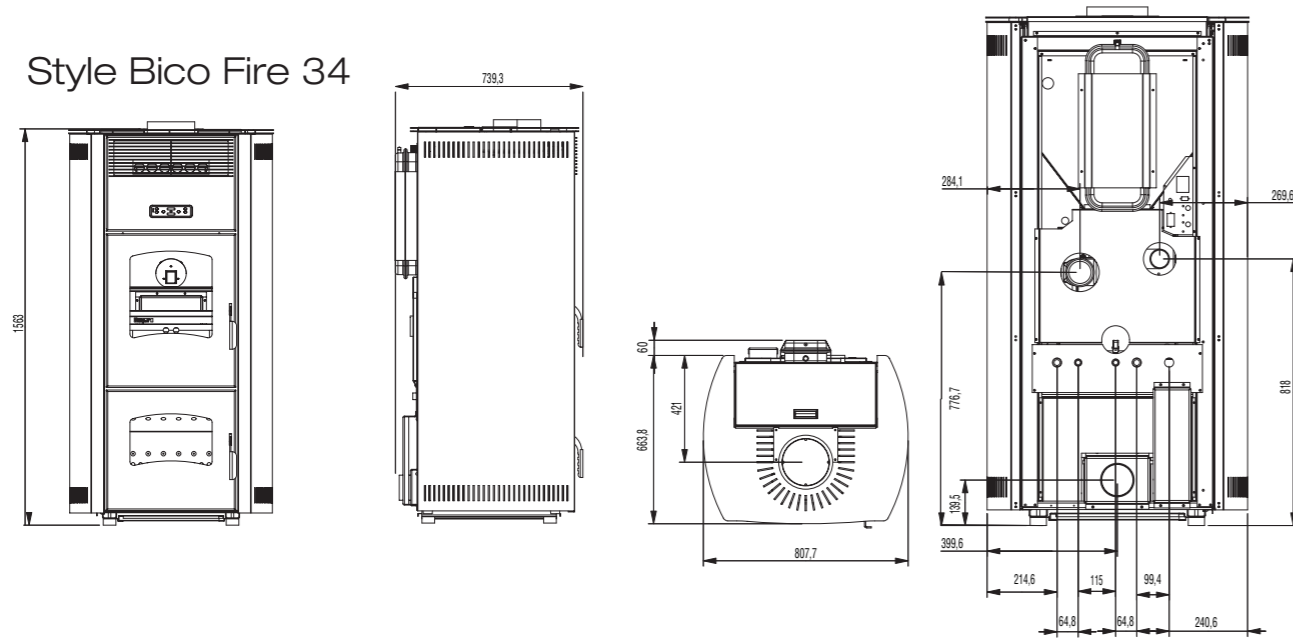

CTU 34

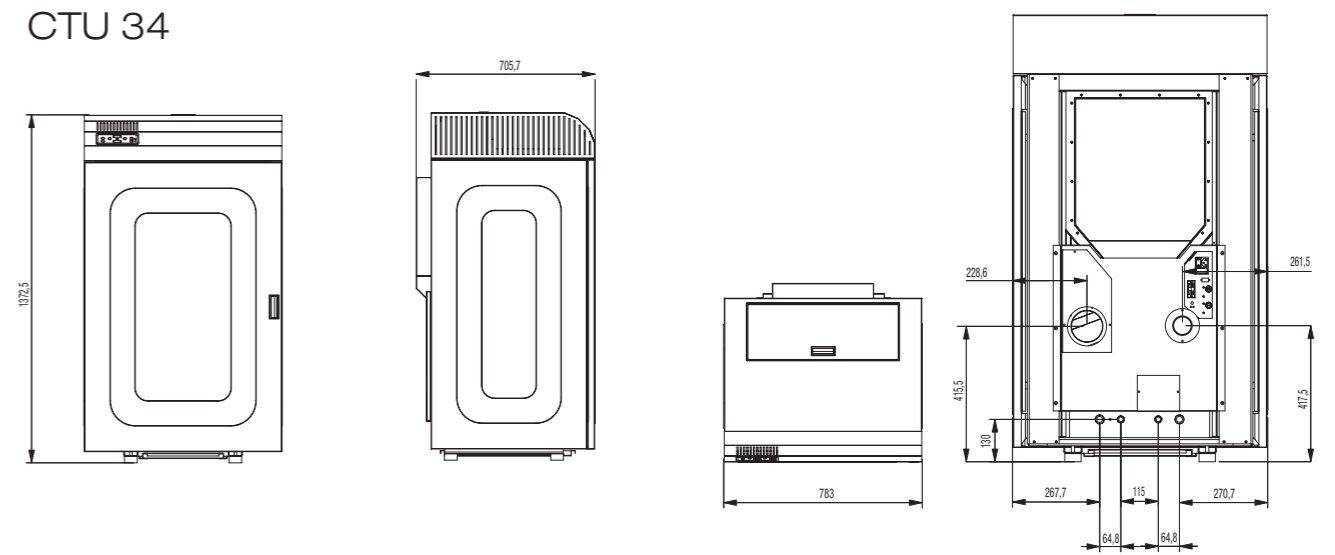

Bico Air 16

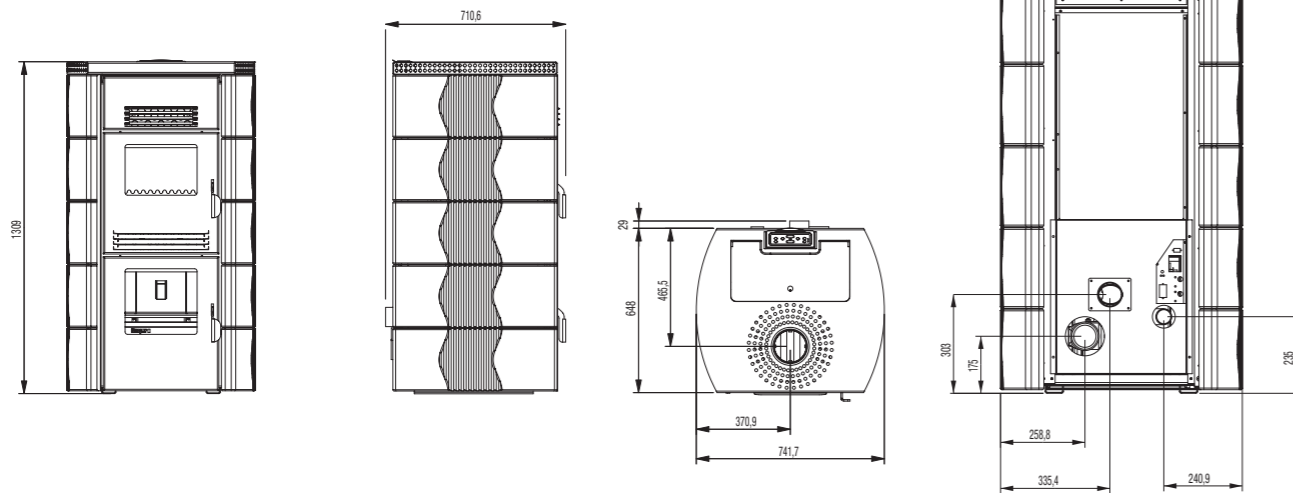

Yncas

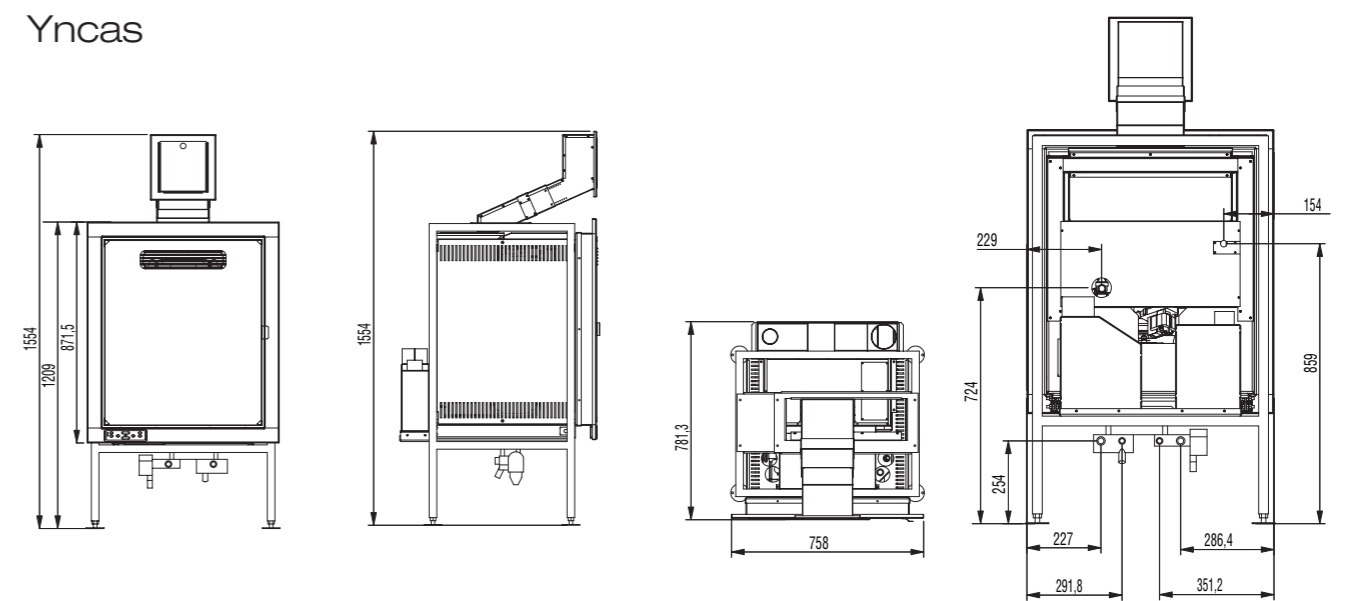

CTU 24

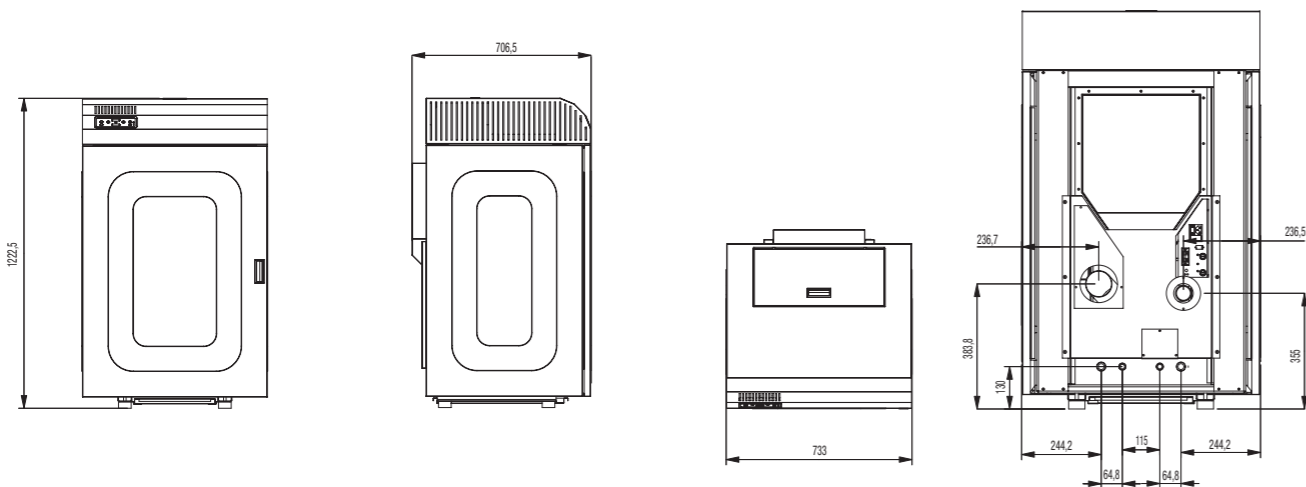

Pedane cristallo / Bases

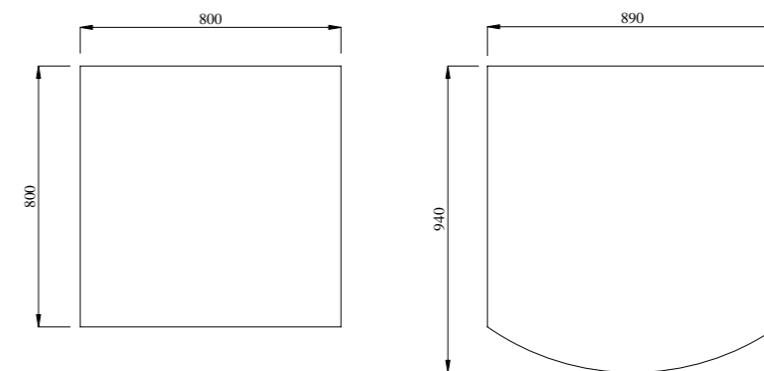

Misure espresse in cm
Dimensions expressed in cm

Esempio di allacciamento idraulico
Hydraulic connection example

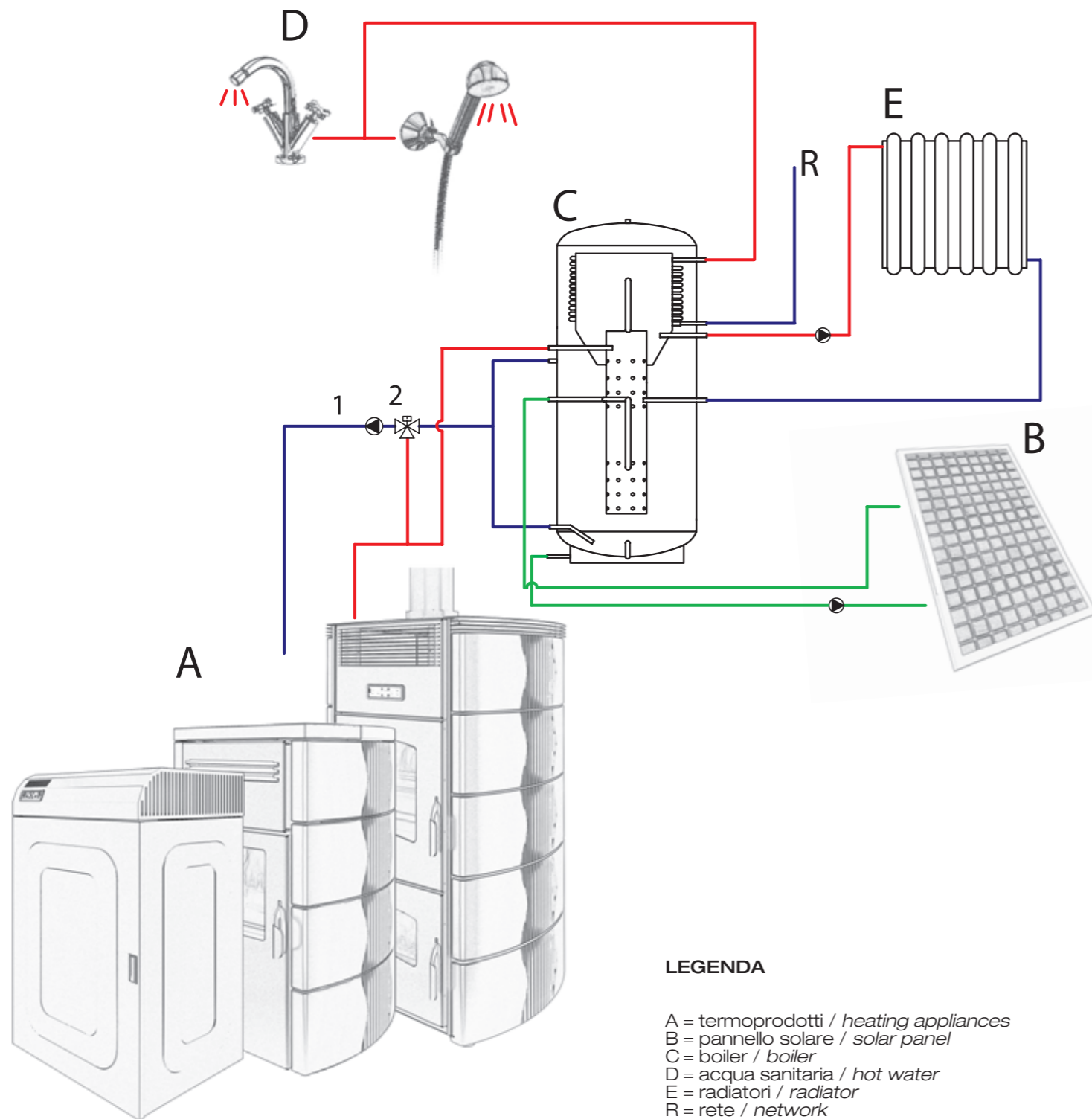

LEGENDA

- A = termoprodotti / heating appliances
- B = pannello solare / solar panel
- C = boiler / boiler
- D = acqua sanitaria / hot water
- E = radiatori / radiator
- R = rete / network

- 1 = circolatore / water pump
- 2 = valvola miscelatrice / mixing valve



Esempio di inserimento/installazione di una termostufa in un appartamento tipo.
Example of water heating stove installation in a apartment.



Esempio installazione canna fumaria legno-pellet.
Example of a pellet-wood flue installation.



Esempio installazione canna fumaria pellet.
Example of a pellet flue installation.

Il presente catalogo annulla e sostituisce i precedenti, potrà essere variato senza preavviso a nostra discrezione.
This current catalogue cancels and substitutes the previous one and could be altered without pre-notification at our own discretion.

